



Arctic Manufacturing Ltd.

3323 Hart Highway, Prince George, B.C. V2K 1M8

ph: (250) 962-9631

fx: (250) 962-7500

www.arcticmfg.com

Tub Type Dump/Gravel Boxes

16'-6" for Tandem Drive and 22' for Tri-Drive Trucks



"E" Model Shown

GB-16600tb-f 16'-6" Tub Type Box

Length: 16'-6" ID Length

7'-5 5/8" ID Width

32" ID Sides

14.13 cu/yrd: A-Frame Lift

GB-22000tb-f 22' Tub Type Box

Length: 22' ID Length

7'-5 5/8" ID Width

32" ID Sides

18.5 cu/yrd: A-Frame Lift

QT-135 Floor and Formed Sides

QT-100 Tail-Gate Skin

Air-Operated Hi-Lift Tail-gate, Hydraulic Operated Hi-Lift Optional

Muncie Hydraulics: Air-Shift PTO, Air-Control Direct Mount Dump Pump, Poly Side Mount 50 gal Tank. 3-Line Hydraulics.

Options:

Air Tarp

Wet Kit/Apron for Mechanical and Air Ride Truck Suspensions

Out-Side Mount Front Ram

Batch Tail-Gate

GB-16600tb 16'-6" Tub Type Box

Length: 16'-6" ID Length

7'-5 5/8" ID Width

41 13/16" ID Sides

15.13 cu/yrd: A-Frame Lift

GB-22000tb 22' Tub Type Box

Length: 22' ID Length

7'-5 5/8" ID Width

41 13/16" ID Sides

20.1 cu/yrd: A-Frame Lift

QT-135 Floor and Formed Sides

QT-100 Tail-Gate Skin

Air-Operated Hi-Lift Tail-gate, Hydraulic Operated Hi-Lift Optional

Muncie Hydraulics: Air-Shift PTO, Air-Control Direct Mount Dump Pump, Poly Side Mount 50 gal Tank. 3-Line Hydraulics.

Options:

Air Tarp

Wet Kit/Apron for Mechanical and Air Ride Truck Suspensions

Out-Side Mount Front Ram

Batch Tail-Gate

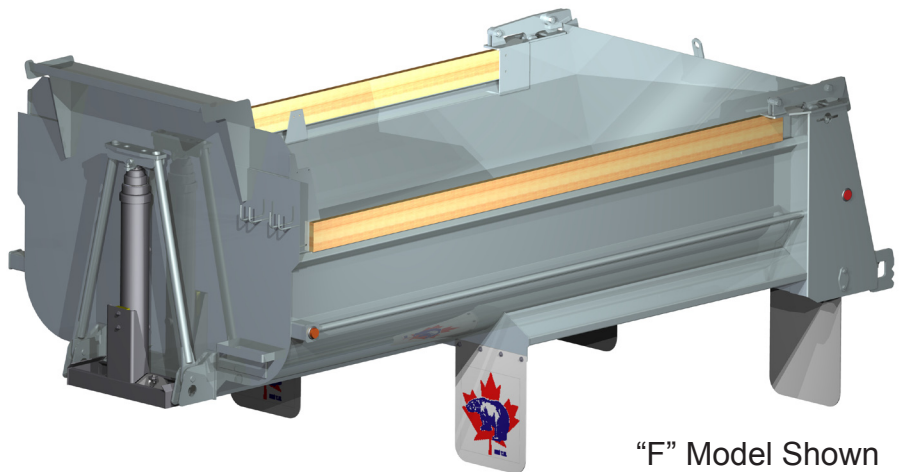

"F" Model Shown

Arctic “Wedge-Lock” Trip Lever Provides Positive Tail-Gate Lock. Features Rising-Rate Lock Force as Latch Lever Arm Closes With Case-Hardened Rollers.

Zerk Fittings on Main Cross-Shaft Pivot Tubes.

QT-100 Formed Long Sills for Increased Strength and Reduced Tare Weight.

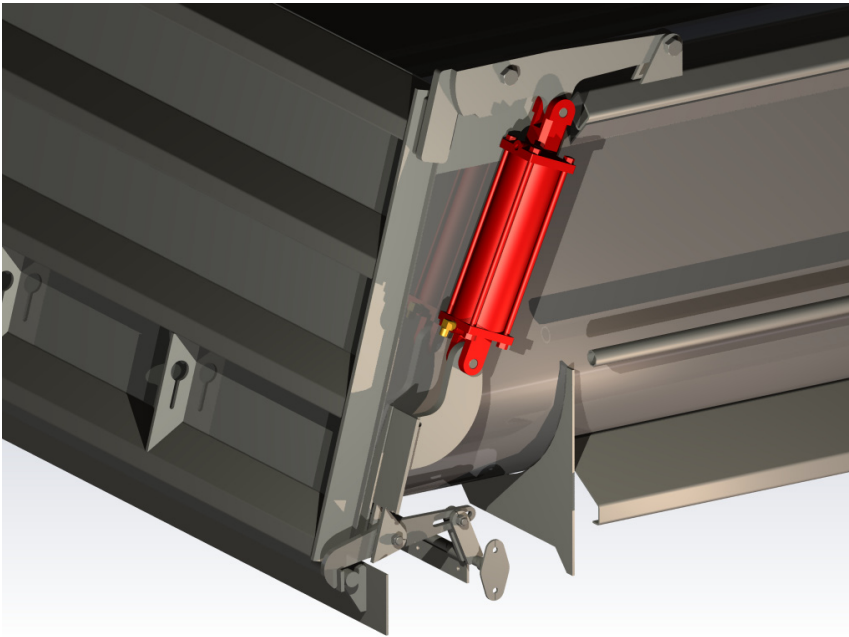
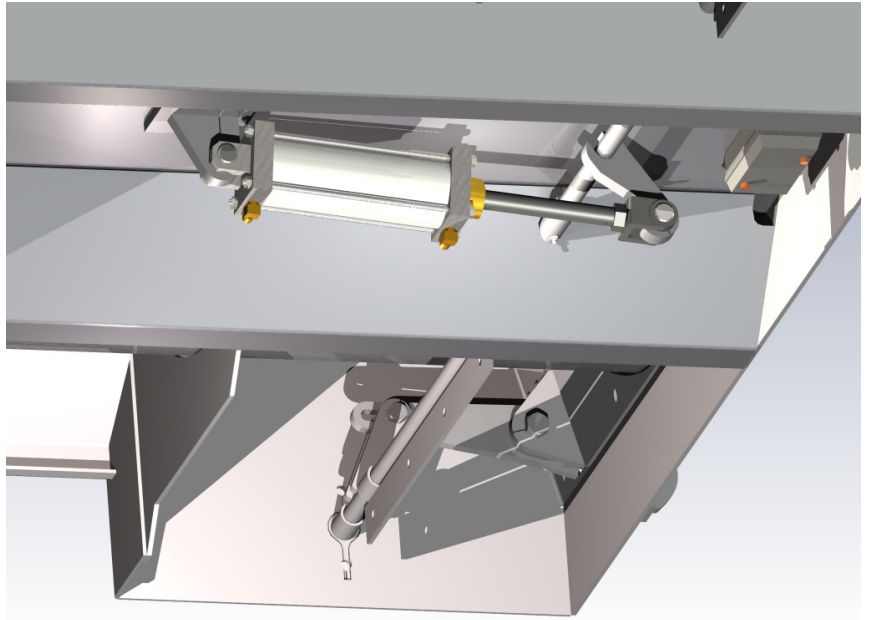

Air-Operated High-Lift Tail-Gate. Provides Damped Tail-Gate Lowering. Simplified Installation on Straight Truck only Installations by Eliminating Remote Spool Valve.

Rams Located in Rear Towers Provides Increased Protection.

All Boxes Feature “Mailhot” Main Lift Rams with “Nitrate Coatings” For Increased Service Life. Optional Ram Configurations Are Available. “A-Frame” Type Front Ram Mount For Pin-Pin Type Rams As Well As Trunnion-Trunnion For “Doghouse” Free Boxes.

Muncie Hydraulic/PTO Units Are Standard. Standard 3-Line and Poly Side Mount 50 gal Tanks Increase Muncie Pump Warranty.

2” Machined Rear Hinge Pins Are Standard On 16’-6” Box Installations And 2 1/2” Machined Rear Hinge Pins Are Standard On 22’ Box Installations.