



Arctic Manufacturing Ltd.

3323 Hart Highway, Prince George, B.C. V2K 1M8

ph: (250) 962-9631

fx: (250) 962-7500

www.arcticmfg.com

HR-48-SFA-B Tridem Straight Frame Hay-Rack

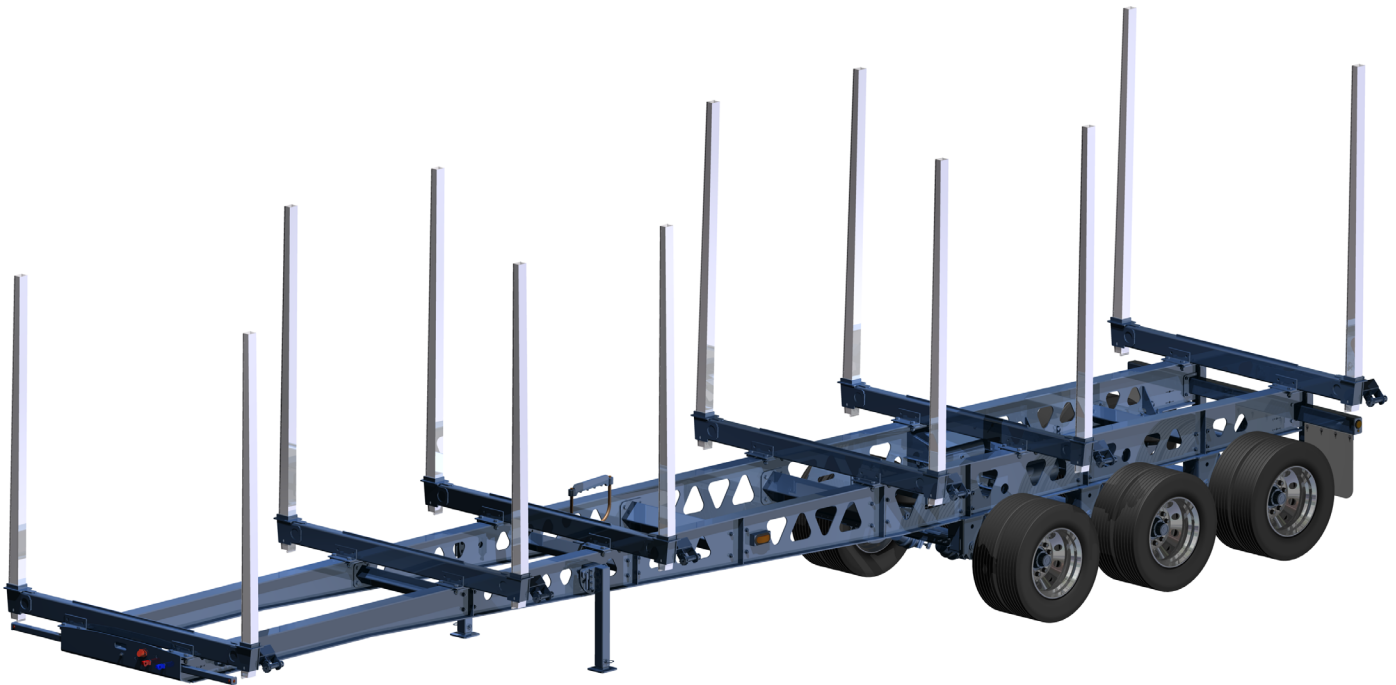

- Chassis:** Heavy Duty Long NeckQT-100 frame, HD Angled cross members. Swing-Up Pin-Type landing gear. Integral suspension limit/restraint straps on all suspensions. Integral Bolt-on rear bumper and light box. Suspension air lines run to front of units for scaling. Available in Under-slung suspension for 7 1/2" reduced frame height.
- Suspension:** Ridewell HS-240 O/S 30,000 lb. Air-Ride suspension. Limit chains on each axle. Liquid filled air gage with primary dump valve. Optional HS-240 U/S 30,000 lb Ridewell suspension.
- Axle:** Dana D22FC-89" track, 3/4" wall with weld-on spiders
- Hubs:** 10-Stud cast hub pilot hubs, with long studs for dual aluminum wheels.
- Drums:** 10 stud cast out-board type 16 1/2" x 7" brake drums.

- Brakes:** CM29 "Q-Type" (23,000lb OEM certifiable G.A.W.R.), enclosed air-ride camshafts with HD snap-rings, Haldex automatic slack adjusters. #30/30 spring brakes Haldex 2S/1M Anti-Lock Brake System on each unit.
- Tires:** Michelin XZY-3 11R24.5 load-range (H).
- Rims:** Alcoa aluminum machine finished 8.25 x 24.5 rims.
- Bunks:** Six movable (AML1210S) 10' Light-Weight 18 ton Bunks, 10-6" HD Stakes with 4" Pockets. Drivers side rear mount winch on each bunk, anchor hook on each bunk, no load straps.
- Air:** "SX" maxi brake air system with anti-compounding full function valves with a "Hostler" Quick release valve
- Legs:** Pin-Type landing gear with swing-up pivot mount.
- Electrical:** C.M.V.S.S. compliance lighting system. Sealed shock resistant lexan tail and clearance/marker lights. Sealed Bobtail receptacles and plugs for all exposed electrical harness. LED tail and marker lights.
- Paint:** DuPont Anti-corrosive zinc high-build epoxy primer with DuPont Imron epoxy single stage two part, same color on frame, axle, hubs. Color: Black. C.M.V.S.S. compliance reflective tape. Media blasted prior to priming/painting.
- Rating:** 61,143 kg G.V.W.R.
- Options:** Light-Weight Hub and Bi-Metal Drums.
Steel Wheel as well as Polished Aluminum Wheels.
11R22.5 Wheel Option.
8'-6" - 10'-6" Short-Log Expandable Bunk Option.
Spring-Loaded Hinged Extension - Drop-In Stake Option.
Rear Bulk-Head and Push-Block Option.

